

## Rotary Movement Device™ – RMD™ Rotary Movement Device Motorized™ – RMDM™



The RMD™ and RMDM™ are used as joints to provide an adjustable offsetting range and increased flexibility of the PLX Lateral Transfer Hollow Periscope™ (LTHP) and Lateral Transfer Hollow Retroreflector™ (LTHR). By coupling multiple units together at their respective entrance and exit apertures you can enable co-alignment of three or more optical axes. The invariant property of the LTHP and LTHR is maintained when connected this way.



Applications for the RMD include

- **Boresighting:** Allowing multiple detectors or imagers to be accurately aligned to a single target for applications in Electro-optic directors and targeting systems.

Thanks to matched CTE optics and PLX proprietary invariant optical technology, accuracy is stable over time/temperature and vibrations, maintaining perfect parallelism with the input beam.

- **Laser beam delivery:** When used within the Articulated Arm Beam Delivery System (AABM), equipped with PLX's precision Hollow Penta Mirrors (HPM), a laser beam can be delivered accurately to any point in 3D space. This could be used in laser machine/engraving applications or optical inspection such as interferometry and flatness measurements.

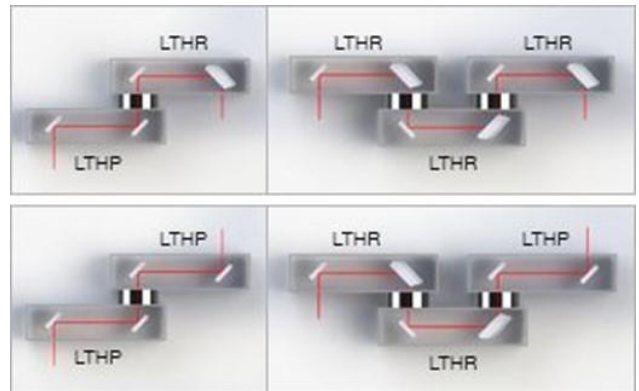

### Important Notice

This datasheet contains typical information specific to products manufactured at the time of its publication. All rights reserved. All material herein is the property of PLX Inc. and shall not be reproduced without the written permission of PLX Inc.

### Applications Demonstrations

PLX provides the RMD integrated to your choice of LTHR(s) and LTHP(s). In this configuration, the exiting beam position can be constantly adjusted to any given distance from the entrance beam while maintaining sub-arc second accuracy, even under harsh environmental conditions.

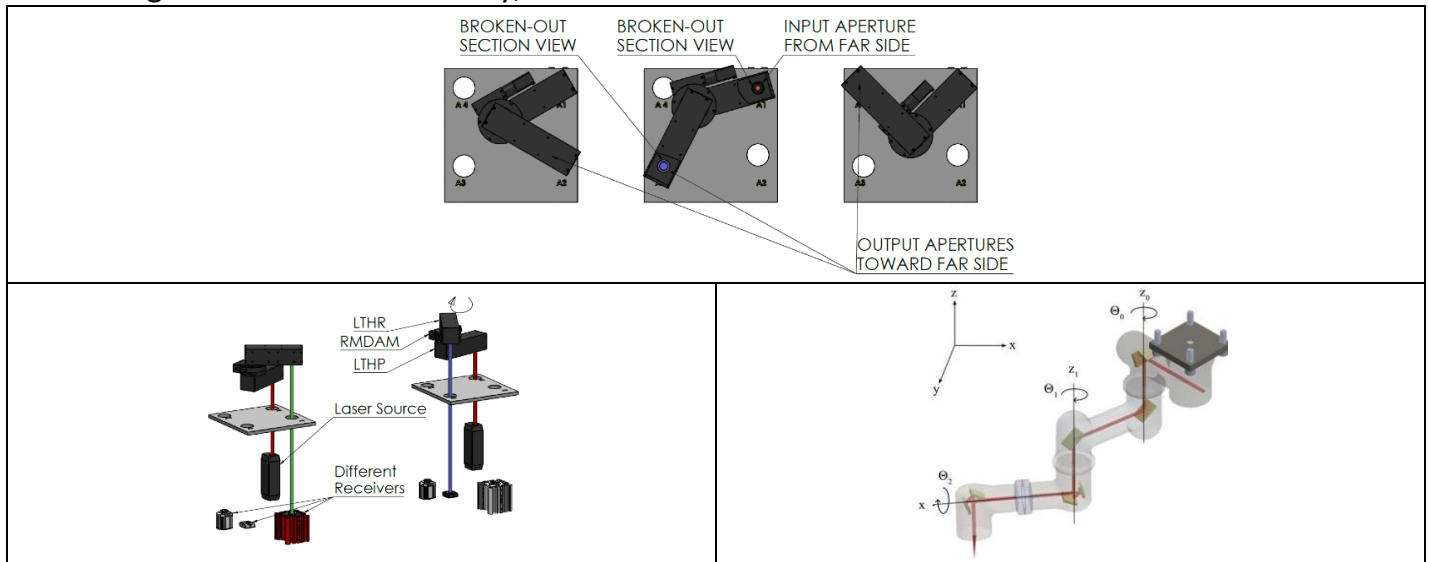

### Instructions

The PLX RMD is available in two different packages, RMD type A(RMDA) and RMD type B(RMDB), and RMDA is available in motorized version (RMDAM)

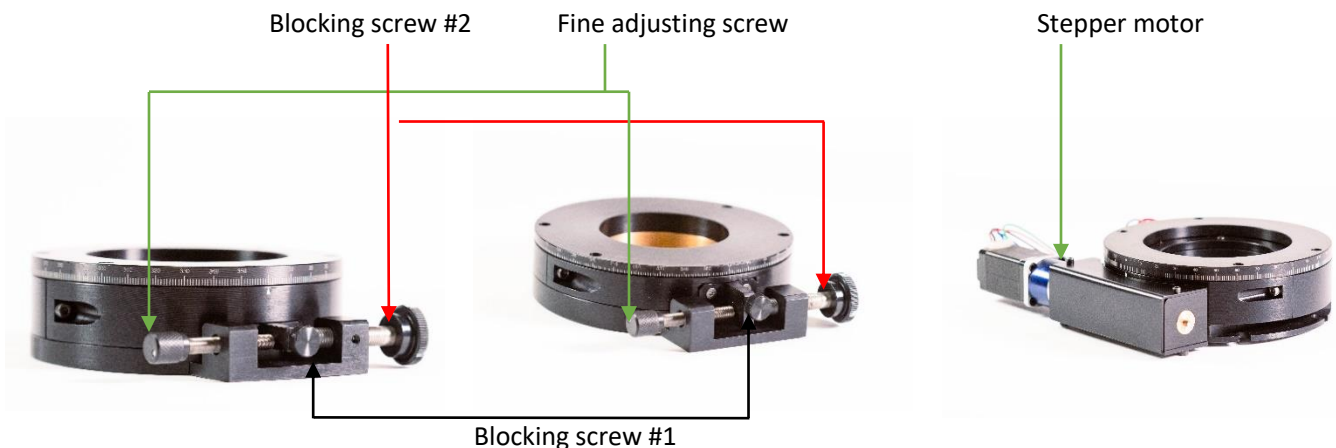

RMDA – Equipped with roller bearing for heavy load	RMDB – Equipped with sleeve bearing for smooth rotation	RMDAM – Motorized version of RMDA
Fast, large rotation when Blocking screw #1 is loosened and precision rotation by fine adjusting screw when it is tightened to activate. Tighten Blocking screw #2 to lock the movement		The movement is controlled by a 5V Stepper Motor, with a metal gearbox